

## Features

01. Ultra-bright LED diving search floodlight and more than 150Meters waterproof.
02. 3xCREE XM-L2 LED High intensity and More than 2960Lumens.
03. The torch features a unique thermostatic circuit to regulate temperature and Prevent over heating.
04. 6 cell 18650 batteries for longer time runtime.
05. Directly charged by AC or DC charger, without taking battery off.
06. Hard-anodizing aerospace-grade aluminum body.
07. High quality watertight O-ring sealed construction.
08. Toughened ultra clear glass lens.
09. Aluminum reflector for a flawless beam.
10. Several groove good heat dispersion.
11. Rubber coating handle, High quality hand strip/lanyard/belt and bag available.
12. Charge and discharge protected Li-ion battery.
13. Magnet control Knob switch moving for on/off or brightness mode change: MAX-MID-LOW-POLICE BLINKING
14. When the battery voltage reduces to a certain value, the light will blink periodically at a frequency of once per minute. The blinking will continue for about for 10-20 minutes before automatically turns off.

## Specifications

Type	W170				W170A			
LED	3XCREE XM-L2 (Cool White)				3XCREE XM-L2 (Neutral White)			
ANSI/FCS	Low	Middle	High	Police blinking	Low	Middle	High	Police blinking
Output(LM)	296LM	1480LM	2960LM	2960LM	260LM	1300LM	2600LM	2600LM
Runtime(Hours) (indoor static testing at 28°C on table)	9.1	6.5	3.4	>3.4	9.1	6.5	3.4	>3.4
Body Color	Black				Golden			
Maximum intensity	120000CD							
Rongne	500M							
Beam angle	9 degree							
Anti-drop	1M							
Waterproof grade	IPX8(150M)							
Dimension	95mm(Head)×66mm×158mm(Length)							
Battery	6*18650 rechargeable Li-ion battery							
Net weight	1378g(battery included)							
Underwater weight	630g(battery included)							
Accessories included	AC Charger/DC charger/Buckle strap/belt/lanyard professional bag/6x18650 Batteries with protection board inside							
Underwater Runtime (At Max. Output)	2.2Hours							

**Runtime declaration :** The data-based duration test in land at room and not in the water.  
If the light use under water or cool condition , the runtime about 1 to 5 times less than instruction.

## Pictorial Overview

\* Photos are for reference only, products in kind prevail!

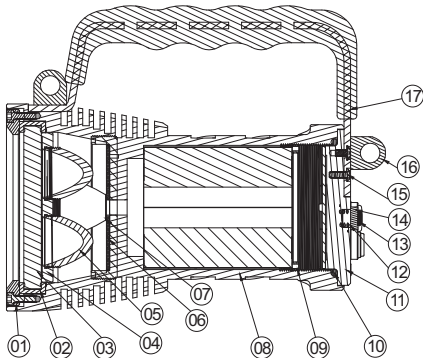

01. front cover
02. rubber ring for lens
03. reflector fixture
04. glass lens
05. reflector
06. PCB board
07. LED cover board
08. main body
09. battery collar
10. O-ring
11. rear cover
12. spring
13. switch rubber
14. switch knob
15. hex socket screw
16. loop for strap
17. handle

## Usage Instructions

The switch knob moved in clockwise and returns to original position when the switch is released, the light is on, To turn the unit off simply repeat the process after 2 Second.

When the light is on, the switch knob moved in clockwise and returns to original position when the switch is released with in 2 second to cycle through the various modes. The menu is structured as follows:

Max-Mid-Low-police blinking.

To save a given mode, simply turn the unit off while in that mode after 2 seconds.

Prior to using the light for the first time the built-in batteries must be fully charged.

While charging, the LED indicator light on the AC power adaptor will illuminate red.

Once the batteries is fully charged the LED indicator will change to green. The built-in

batteries of light can take up to 6 hours to charge if fully depleted. Alternatively the batteries may be charged for 4 hours to 80% or 5 hours to 90%. While the built-in batteries of light can be used in any state of charge higher than the 8.5v cut-off, when not used for extended periods, it should be charged for 4 hours every 3 months. After each 3 monthly charge, it is also recommended that the light be used on high for 10-20 minutes before storing.

**Low Voltage Warning and Cut-Off:** When battery capacity reaches about 20%, the light will have a 10-20 minutes blinking period at a frequency of once per minute. When the battery voltage reaches 8.5V, the protection circuit will be activated and and the light will automatically shut off. The light can be used again until next recharge.

## Intelligent Temperature Control Instructions

This product is designed with a temperature control circuit. The LED is a heating device that is sensitive to temperatures, especially high levels of power and brightness. High temperatures will easily damage or shorten the life of the LED. Ferei designs its products with an intelligent temperature-control circuit. It measures the temperature within the LED filament. As the structure of the lamp differs, the thermal conductivity of the entire lamp is not the same. In general, the constant surface temperature of the lamp is 50°C to 60°C. When it exceeds its programmed temperature, it will automatically reduce its power to cool down , and the brightness decreases by small steps. After cooling-down (provided that battery voltage is sufficient) the power with brightness increases again. The process of improving its brightness is relatively discrete and will not produce a flashing effect.

This stepping goes cyclically to maintain the user's safety and the light's functionality. In conditions of good air-cooling the lamp delivers light without stepping down even in high levels brightness mode. There are no preset timers for stepping, but real-time active temperature measurements. So the actual runtime of the lamp base on active temperature control to faster or slower battery discharge, may be slightly longer or shorter runtime than the lamp of data provided .

## Maintenance

1. Periodically Clean the glass lens of dust and debris to ensure maximum brightness. Use a soft clean cloth or an eyeglass cleaner if possible to avoid scratching the glass.
2. Be sure to rinse the light thoroughly with fresh water after every use in saltwater

### Note:

Never disassemble the head or touch the inside of the reflector.

## Precautions and Warnings

- The W170 has a highly intense beam and should not be aimed directly at the eyes of human
- Please ensure all screws tighten before diving, otherwise water will go into the dive lights
- The surface of the light may become hot during extended use. Avoid touching these areas
- Do not dismantle or disassemble any part of the light as this will void warranty and affect the waterproof seal
- Rinse the lights surface with fresh water and dry with soft cloth after exposure to saltwater or any corrosive substance
- The W170's power source is a 11.1V lithium-ion battery pack coupled with a protection circuit board. Should the battery pack ever fail to charge or cease normal operation be sure to contact you local Ferei dealer and under no circumstances attempt self-repair
- Always recharge W170 with the provided Ferei AC/DC adapter. Never connect it with 110V or 240V AC power directly as this will cause damage of the product
- Ferei reserves the right of interpretation of this manual

☆☆☆ patented product, counterfeiting not allowed ☆☆☆

## Shenzhen FEREI Lighting Co., Ltd

Address:3rd Industrial Zone, Xiakeng Village, Tongle, Longgang District, Shenzhen 518116 China

TEL: 0086 755 8480 7942 / 0086 755 8480 7943

FAX: 0086 755 8480 7944 E-mail: ferei@ferei.com

Web: http://www.ferei.com